

**CT BOLLARD**

# Specification

**Product ID**  
 VED / 0054

**Description**

CT30SH N2 Mild Steel PAS 68 Counter Terror Bollard with Integral Re-bar Cage - Galvanisid Finish.

The CT30SH N2 is a shallow foundation, high security bollard designed to mitigate a vehicle attack at 48kph. Normal spacing for bollards will be 1200mm. The bollard has been successfully tested and approved to the following classification:

**PAS68: 2010 V/7500(N2)/48/90.1.1/0.0**

**Installation**

For advice about installation of this product, please contact our sales office.

**Dimensions**

If dimensions are critical please contact sales to confirm

**Brand:** CT Bollard  
**Category:** Vehicle Defence  
**Sub Category:** Below Ground  
**Material:** Mild Steel  
**Max Dia:** 219mm  
**Above Ground Height:** 1000mm  
**Below Ground:** 400mm  
**Units:** Each

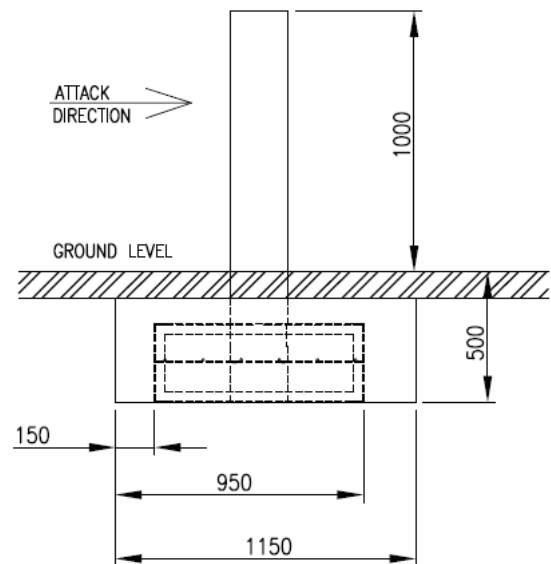
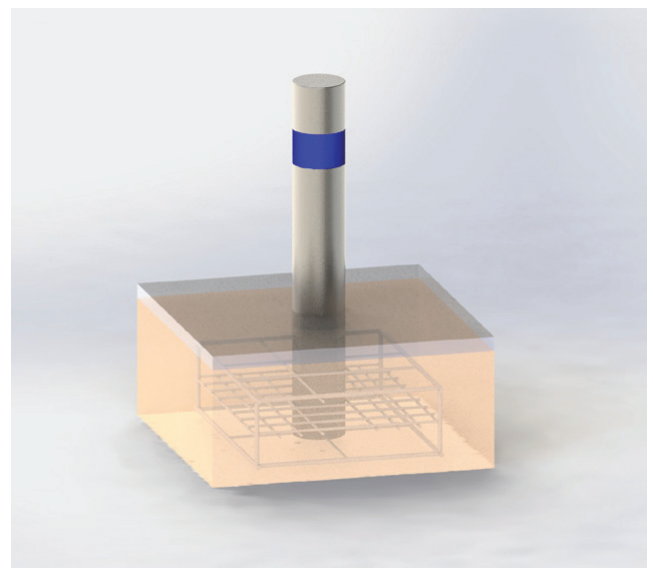

**Policy**

Townscape's policy is one of continuous development, and we reserve the right to modify design specification or price without notice. The copyright, design rights and other intellectual property rights in the products and drawings shown and in the text displayed are the property of Townscape Products Limited.

All sizes and weights are nominal and the Company reserves the right to modify dimensions without notice. If dimensions or weights are critical please state when ordering.

