

# Specification

## Product ID

BOL / 0287

### Description

Melton Concrete Bollard - Below Ground Fix  
 Finished in any of the Smooth Prestige Mixes.  
 This product can be supplied in the following aggregate colour mixes.  
 Smooth Prestige Mixes: White PP09, Black PP32, Yorkstone PP02, Cloburn Red PP48 and Grey PP08  
 Please confirm the required colour mix at the point of order.

### Dimensions

If dimensions are critical please contact sales to confirm

<b>Brand:</b>	Melton
<b>Category:</b>	Bollards
<b>Sub Category:</b>	Below Ground
<b>Material:</b>	Concrete
<b>Max Dia:</b>	300mm
<b>Above Ground:</b>	520mm
<b>Below Ground:</b>	390mm
<b>Overall Height:</b>	910mm
<b>Weight:</b>	100kg
<b>Units:</b>	Each

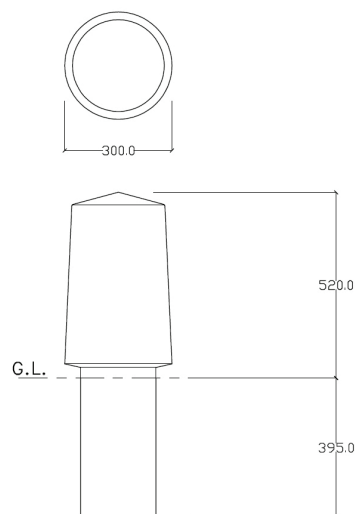

### Policy

Townscape's policy is one of continuous development, and we reserve the right to modify design specification or price without notice. The copyright, design rights and other intellectual property rights in the products and drawings shown and in the text displayed are the property of Townscape Products Limited.  
 All sizes and weights are nominal and the Company reserves the right to modify dimensions without notice. If dimensions or weights are critical please state when ordering.

### Smooth Prestige Mixes:

