

**CT STREET FURNITURE**

# Specification

**Product ID**  
 VED / 0033 50SM

**Description**  
 Wessex PAS 68 CT50 Stainless Steel (Grade 316) Cycle Stand - Below Ground Fix - Utilises a CT 50 Shallow Mount Bollard.

This product is IWA14 approved to the following classifications:  
**50mph Test - Fixed Bollard: IWA 14 V/7200/80/90:8.7**

**Installation**  
 For advice about installation of this product, please contact our sales office

**Dimensions**  
 If dimensions are critical please contact sales to confirm

**Brand:** Wessex  
**Category:** Vehicle Defence  
**Sub Category:** Cycle Stand  
**Material:** Stainless Steel  
**Max Width:** 1076mm  
**Above Ground:** 1003mm  
**Below Ground:** 200mm  
**Units:** Each

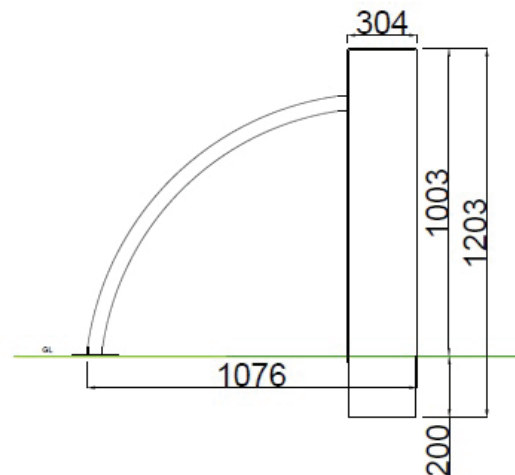

**Policy**  
 Townscape's policy is one of continuous development, and we reserve the right to modify design specification or price without notice. The copyright, design rights and other intellectual property rights in the products and drawings shown and in the text displayed are the property of Townscape Products Limited.

All sizes and weights are nominal and the Company reserves the right to modify dimensions without notice.  
 If dimensions or weights are critical please state when ordering.

